



P1 Dual Monaural Phono Stage

User Manual





Dear Valued Customer,

We are honored that you chose the P1 Dual Monaural Phono Stage for your audio system. Our team devoted their best efforts to design and manufacture this top quality versatile and future-proof product and is proud to present it to you. We hope your P1 phono stage will bring you uncountable hours of emotion from your music collection.

But before you embark on your musical journey, we kindly request your attention to the information contained in this manual. The P1, as you will discover in the following pages, is a Swiss precision product designed for ultimate performance and flexibility. However, reaching sonic excellence requires your unit to be set up and operated correctly and this what this manual is all about. If you have any questions or require assistance, please don't hesitate to contact your authorized dealer.

We hope you will enjoy your P1 phono stage for many years.

The Concert has just begun...

Cossy F.

A handwritten signature in blue ink, consisting of a stylized 'C' followed by a horizontal line and a vertical stroke.

Heeb T.

A handwritten signature in blue ink, featuring a large, looped 'H' followed by a horizontal line and a vertical stroke.





Table of contents

1	Phono stage highlights.....	7
1.1	Input stage.....	8
1.2	RIAA playback equalization.....	8
1.3	Voltage input impedance loading: helpful guidance from your P1	9
1.4	Careful metal work construction.....	9
1.5	Power supply.....	10
2	System Setups.....	11
2.1	Dual Monaural setup.....	11
2.2	True Monaural setup.....	12
3	Read carefully before use.....	13
3.1	Package content.....	13
3.2	Safety notice.....	13
3.3	Mains supply.....	14
3.4	Transport and packaging.....	14
3.5	Cleaning.....	14
3.6	Maintenance and Servicing.....	14
4	Installation.....	15
4.1	Unpacking.....	15
4.2	Unit positioning.....	15
5	Connections.....	17
5.1	Audio connections.....	18
5.2	Ground connection.....	19
5.3	X1 optional External Power Supply connector.....	19
5.4	Ethernet port.....	19
5.5	Mains socket and voltage selection.....	19
5.6	USB port.....	19
6	Operation.....	20
6.1	Front panel.....	20
6.2	Front panel push-buttons.....	21
6.3	Operating modes.....	21
6.3.1	Normal mode.....	21
6.3.2	Shortcut Mode.....	23
6.3.3	Menu mode.....	24
7	Unit menus.....	28
7.1	AUDIO SETTINGS menu.....	28
7.2	DISPLAY SETTINGS menu.....	29
7.3	SHORTCUTS menu.....	30
7.4	FACTORY SETTINGS menu.....	30
7.5	INSTALLED OPTIONS menu.....	31
7.6	NETWORK SETTINGS menu.....	31
8	Adjust the P1 to the cartridge.....	33
8.1	Input type selection.....	33
8.2	Initial loading selection.....	33
8.3	Optimal gain selection.....	33
8.4	Refined loading selection.....	33



9	Firmware update.....	34
9.1	Preparing the USB Stick.....	34
9.2	Updating the unit's firmware.....	34
9.3	Emergency firmware update procedure.....	34
10	Troubleshooting.....	35
11	Specifications.....	36

1 Phono stage highlights

CH products are proudly designed and manufactured in Switzerland by CH Precision Sàrl. Our engineers combined all their know-how, expertise and ingeniousness to bring you the P1, a top performance future-proof modular two channel phono stage with Ethernet control capabilities and USB flash-drive firmware update. Like every CH Precision products, the P1 is versatile: two configurations are possible: Dual Monaural (the P1 holds the Left and Right channels in a single chassis) or True Monaural (two P1s work together, each one processing a single channel, one phono stage board in each chassis). These configurations can be further enhanced with the addition of one or two X1 External power supply units.

The P1 is a pure Class A discrete transistor based circuitry. This results in ultra low noise, high bandwidth and high slew rate performances. The signal stays in the analog domain all the way through.

The P1 provides 3 inputs, two of which are in current mode, dedicated to MC cartridges. The third input is in voltage mode, accommodating both MM and MC cartridges as well as step-up transformers. The MC1 and MC2 current mode inputs require no impedance matching. However, the MM/MC voltage mode input is fitted with a variable resistor seen by the connected cartridge as a load for impedance matching. All the inputs have multiple gain settings.

The P1 holds the standard RIAA playback equalization filter. On top of it, a set of other EQ filters (EMI, Columbia, Teldec and Decca) is available as an option that can be factory fitted or retrofitted to the unit.

A bypassable subsonic high-pass filter can be inserted in the signal chain to remove unwanted rumble and very low frequency noises.

The P1 uses tight tolerance, high-grade metal film resistors throughout the audio signal path as well as custom high grade film capacitors in the filtering sections.

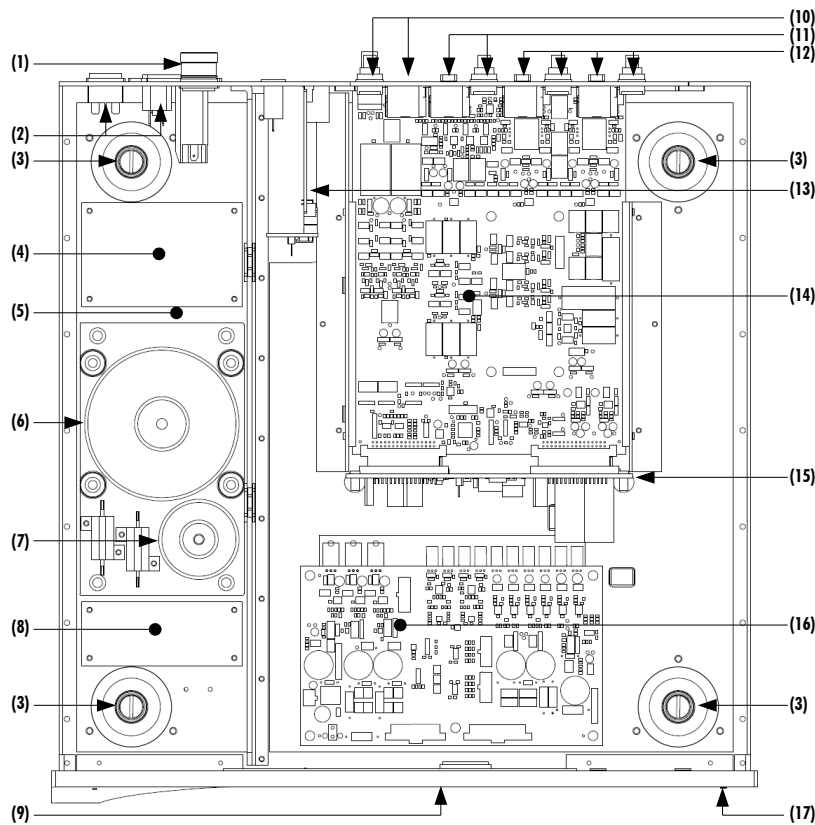

P1 main components



- (1) External power supply input. For X1 optional external power supply only
- (2) Mains switch and power cord receptacle (on back panel)
- (3) Adjustment shafts and screws
- (4) Mains filter board
- (5) Power supply section
- (6) Main power transformer
- (7) Standby power transformer (ensures green mode standby)
- (8) Front panel power supply board
- (9) Display (on front panel)
- (10) Balanced and single-ended outputs
- (11) XLR/RCA connectors for the MM/MC voltage input. Only the XLR or the RCA can be connected to a cartridge at a time
- (12) XLR/RCA connectors for the two MC current inputs. For each input (MC1 and MC2), only the XLR or the RCA can be connected to a cartridge at a time
- (13) Control board (USB plug for firmware update and Ethernet RJ-45 plug for control from Android App)
- (14) Single-channel phonostage board (one or two per unit)
- (15) Backplane board
- (16) Power supply regulation board
- (17) User interface push-buttons

1.1 Input stage

Three inputs are available on the P1. Two of them are in current mode, dedicated to MC cartridges. The third input is in voltage mode, accommodating both MM and MC cartridges as well as step-up transformers.

- **MC1 and MC2 Current mode input:** a current mode input reads the current generated by the cartridge (not its voltage). Current mode inputs are usually dedicated to MC cartridges. The current from the cartridge is amplified by a discrete transistor based trans-impedance amplifier. Using current mode inputs provide a superior signal to noise ratio compared to a conventional voltage input, better immunity and by essence no necessity to match impedance. The gain of the trans-impedance amplifier is intrinsically dependent on the cartridge internal resistance. The lower the cartridge internal resistance, the higher the gain. Multiple gain settings are available on each input to accommodate the variation of resistance among cartridges.
- **MM/MC Voltage mode input:** a voltage mode input reads the voltage generated by the cartridge. The voltage mode input is used for all types of cartridges as well as with step-up transformers. The cartridge output signal is amplified by a voltage amplifier. The input is fitted with a user-variable resistive load (variable between 20 Ohms and 100 kOhms), allowing to adjust the cartridge loading impedance and providing a frequency response as flat as the setup will allow. In order to assist the user to set up his system, the P1 comes with a feature that measures the frequency response of the system (cartridge, cables and P1 input) and displays a series of graphs showing the flatness of the system.

1.2 RIAA playback equalization

RIAA playback equalization is a specification for the playback of phonograph records. The P1 is fitted with a passive implementation of the RIAA equalization, using high grade, high tolerance metal film resistors and custom made film capacitors. The RIAA equalization provides an accurate filtering for the playback of all the discs recorded with the RIAA equalization. However, older records (up to the mid 50's and sometimes later) were recorded using different equalization. The P1 can be fitted with an optional board that contains 4 extra equalization filters: Columbia, EMI, Decca and Teldec. Please refer to your local dealer for



more information about ordering or installing the optional board into your P1 unit.

The enhanced RIAA curve: the unofficial Neumann time constant can be enabled by the user and is added to the RIAA equalization. It is displayed on the unit's screen with the letter "e" preceding the standard filter: "eRIAA".

1.3 Voltage input impedance loading: helpful guidance from your P1

Manufacturers often specify a recommended loading value or range that best matches their cartridge. This is the optimal impedance that should electrically load the cartridge.

If an impedance of that value is simply added in parallel to the phono stage input circuitry, sub-optimal results are often obtained. The main reason is that the actual loading seen by the cartridge is the combination of the impedance of the cable, the input impedance of the phono stage input and the variable loading that phono stage manufacturers usually provide. Moreover, some cartridge/tonerarm pairs can also exhibit resonance in the audio band, which can be seen as accidents (peaks or dips) in the frequency response. Such ringing can also be slightly tamed by proper cartridge electrical loading.

In order to help our customer to optimally load their cartridge, the P1 phono stage comes with a 45 RPM test record. Side 1 contains a 250Hz-30kHz filtered pink noise track designed to be used in conjunction with a wizard available from the P1's menu. The wizard allows to analyze the frequency response of the entire system (cartridge + tonearm + P1 input loading), while varying the resistive loading of the P1's voltage input. Users can select to test the entire [20 Ohm – 100 kOhm] range that the P1 provides, or any subset of that range for finer tuning. The P1 automatically acquires 21 different frequency response curves applying input loadings scattered across the range selected in the previous step.

In addition to the frequency response curve for each loading value, an average level and a measurement of the flatness of each curve (standard deviation) is also provided guidance.

As a general rule of thumb, user should start by analyzing the entire possible loading range when a step-up transformer is used, or when no recommended loading is provided by the cartridge manufacturer. If only a minimal loading value is defined, users are welcomed to analyze all values above this specification. In other cases, one can start around the recommended value, roughly from half to twice this value. Iterative calls of the loading wizard, while refining the analyzed range is recommended to find optimal loading.

Proper loading should meet the following criteria:

- Average level drop shouldn't exceed 2 to 3 dB compared with the 100 kOhm loading setup
- Most extended frequency response
- Maximum flatness of the frequency response (flatness value should be as low as possible)

Once a set of acquisitions is completed, users can browse through analyzed loading values both visually (seeing the corresponding frequency response curves) and sonically (listening to the effect of each loading value while playing any record).

1.4 Careful metal work construction

The P1 phono stage chassis is made of high grade aluminum alloy with no visible screws on the front, top and side panels. First class mechanical and chemical surface treatments provide the luxury finish of the P1. Pin assembly of all chassis elements enables smooth joints between metal parts while screws every 6cm ensure protection against electromagnetic interferences.

Four stainless steel feet support the unit. Each foot is fitted with an elastomer ring to sit on delicate surfaces but is also equipped with height adjustable hardened steel spikes to fine tune the unit position. Horizontal leveling is accomplished using the provided screwdriver through the four adjustment shafts accessible from the top of the unit. Moreover, the steel spikes serve as vibration evacuation channels in a stack of units. Special covers are provided to interface with the spikes of the unit above (see section 4.2).



Vibrations from the upper unit is transmitted by the stacking cover to the shaft of the lower unit and from there to the lower unit's feet or spikes, forming a privileged path for vibrations evacuation.

1.5 Power supply

The power supply of the P1 is a linear supply with multiple independent local regulation circuits.

The largest mains transformer is an oversized toroidal transformer and is used to supply power to the local regulation circuits, which in turns, supply both phono stage boards. The transformer also supplies power to the digital areas of the unit (front panel display, microcontroller and Digital Signal Processing devices - DSP - that monitor the unit).

Discrete ultra low noise regulators are used throughout the power supply to ensure the purest low noise DC feed possible to the different audio sections. Each phono stage board enjoys dedicated analog regulators.

The second, smaller toroidal transformer inside the P1 is used as the Standby transformer to ensure green Standby mode, meeting the latest energy saving regulations.

Both transformers have static shields between primary and secondary windings. They are mounted on a steel plate which is isolated from the rest of the chassis by silent blocks to prevent vibration transmission to the unit.

Input AC voltage to the power supply can be set to 100V, 115V or 230V AC according to your local mains voltage.

2 System Setups

The following setups can be realized.

2.1 Dual Monaural setup

In this setup, a single P1 enclosure is used to hold the Left and Right channels. Two boards are fitted inside its chassis, each one independently processing a single channel. The mains power supply section is common to both the board, however separate dedicated DC regulation circuits are used for each board. For ultimate performances, the X1 External Power Supply unit should be added to the setup.

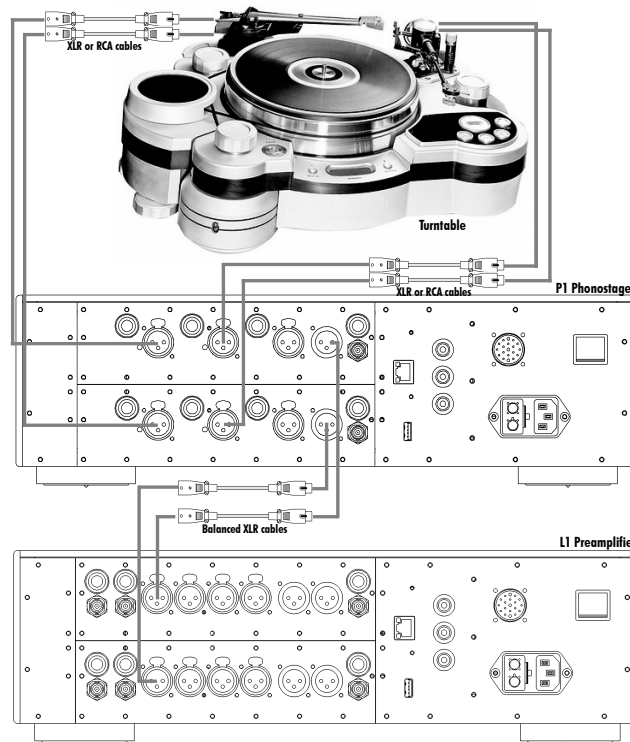

Dual Monaural setup

2.2 True Monaural setup

In this setup, two P1 s enclosures are used to hold a single channel each (Left respectively Right). The entire power supply of each P1 is dedicated to one channel, further enhancing the system performances. Both P1 s should be connected to a network via a router to ensure all audio settings (such as gain, selected input, cartridge loading) are synchronized between units. For ultimate performances, up to two X1 External Power Supply unit should be added to the setup.

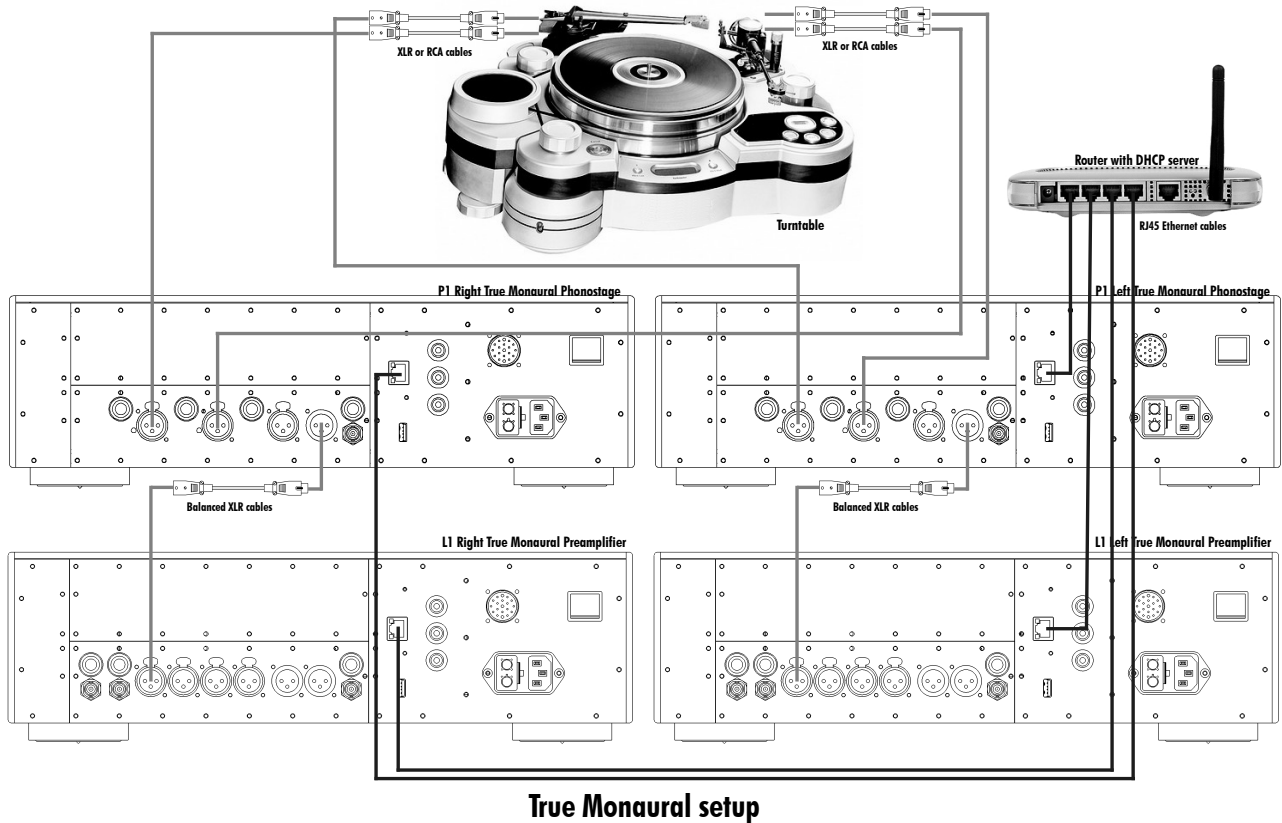



3 Read carefully before use

Please read this manual carefully before making connections or operating your P1 phono stage. After reading this manual, please store it in an accessible place for future reference. If, after reading this manual, you feel unsure about how to make connections or how to operate the unit, please contact your authorized dealer for assistance.

3.1 Package content

Make sure that the package content is complete. If not, please contact your authorized dealer. Your package contains:

- The P1 phono stage unit
- A power cord
- Four adjustment steel spikes
- Two 4mm banana plugs
- A suction cup (used to unscrew the top covers)
- An accessory box containing:
 - a spike adjustment screwdriver
 - a Torx T10 screwdriver
 - four steel stacking covers
 - a USB stick containing the latest CH Precision firmwares.
 - four CH Support Discs

Please store the packaging for future use. Check your P1 phono stage for any apparent damage. In case of a damage, please contact your authorized dealer. If your P1 phono stage is still very cold due to transport, please let it warm up to room temperature in order to avoid condensation inside the unit.

3.2 Safety notice

Make sure to observe the following rules:

- Always keep the unit horizontal when handling it
- Install your P1 phono stage on a stable base
- Do not install your P1 phono stage near water
- Always handle with care. The P1 phono stage is fairly heavy, so have someone to help you when moving it around
- Do not expose the unit to any kind of liquid
- Do not install it under direct sunlight or near any heat source such as radiators or other apparatus generating heat
- Do not install it in a confined space and make sure there is sufficient airflow around the unit, including under the unit.
- Do not operate under high ambient temperature (>40°C) or in extremely high humidity conditions
- Only use options and accessories specified or recommended by CH Precision
- Do not open the unit nor try to service it by yourself. Always refer to a qualified technician for service, maintenance or



upgrades. Failure to do so will void the unit's warranty

3.3 Mains supply

Before connecting the mains power cord, make sure that the mains voltage selection at the back of the unit matches your local mains voltage.

Make sure your P1 phono stage is disconnected from the AC wall socket in the following cases:

- When cleaning the unit
- During thunderstorms
- When unused for a long period of time

Also make sure your P1 phono stage is turned off when making audio connections (it is also recommended to turn off the rest of the system).

3.4 Transport and packaging

The P1 phono stage must always be stored in its original packaging for transportation. Doing so will ensure an optimal level of protection for your unit. Please keep all packaging in a dry and clean place for future use.

Besides, we recommend to remove the adjustment spikes and to put them in the packaging box prior transportation. Vibrations during transport may cause the adjustment spikes to move from their retracted position; there could be a risk of damaging the piece of furniture the unit is installed onto if the spikes are not fully retracted.

3.5 Cleaning

Use a soft, dry cloth for cleaning. Never use any solvent or liquids as they may damage the surface or infiltrate the unit. Please use an ultra-soft piece of fabric designed to clean eyeglasses for the front display area.

3.6 Maintenance and Servicing

The P1 phono stage contains no user serviceable parts. Do not try to open, modify or repair your P1 by yourself. This will void any warranty. Your P1 phono stage must be checked by a qualified technician in any of the following cases:

- The unit is malfunctioning
- The power cord or mains plug at the back of the unit is damaged
- The unit was dropped to the floor or presents external damage
- The P1 phono stage has been exposed to liquids or unknown substances

4 Installation

4.1 Unpacking

Unpack your P1 phono stage and store the packaging for future use. The P1 phono stage is fairly heavy, so have someone to help you when removing it from its packaging.

4.2 Unit positioning

When delivered from factory, the P1 phono stage's four feet sit on elastomer rings, ensuring both scratch-protection for the base on which the unit sits, as well as safe anti-slipping unit positioning.

But a more advanced vibration-channeling mechanical coupling can be implemented, thanks to the steel spikes and the polymer support discs provided with the P1. To use this optimal coupling, simply go through the following steps:

1. Place the P1 unit on a stable base at its approximate final position, for instance in your preferred audio rack. Make sure cooling air is able to freely flow around the unit.
2. Gently lift the unit's corners and insert a support disc under each foot. The foot's elastomer ring should disappear in the support disc's groove when properly placed. Carefully check all four feet perfectly fit in each support disc before pursuing any further. The unit should stably rest on its feet at that point.
3. Unscrew the four top covers from the P1's shafts with the provided suction cup. Be careful not to scratch their delicate finish.
4. Insert the adjustment spikes into each adjustment shaft.
5. Softly screw clockwise each adjustment spikes into the shaft with the provided screwdriver, until any resistance is felt (just before the unit's corner starts to lift).
6. Then screw clockwise each spike by the same amount (for instance two full turns).
7. If the base is flat, the unit should be stable and horizontal. If not, correct the unit's stability and horizontality by turning clockwise or anti-clockwise the required spikes.

If no CH Precision unit is to be stacked on top of the P1, screw the four top covers back. Otherwise, screw the four polymer stacking caps instead, and gently lay down the unit to be stacked on top of it. Be very careful that both units are perfectly aligned in order not to scratch the P1's top plate with the other unit's feet. Repeat steps 3 to 8.

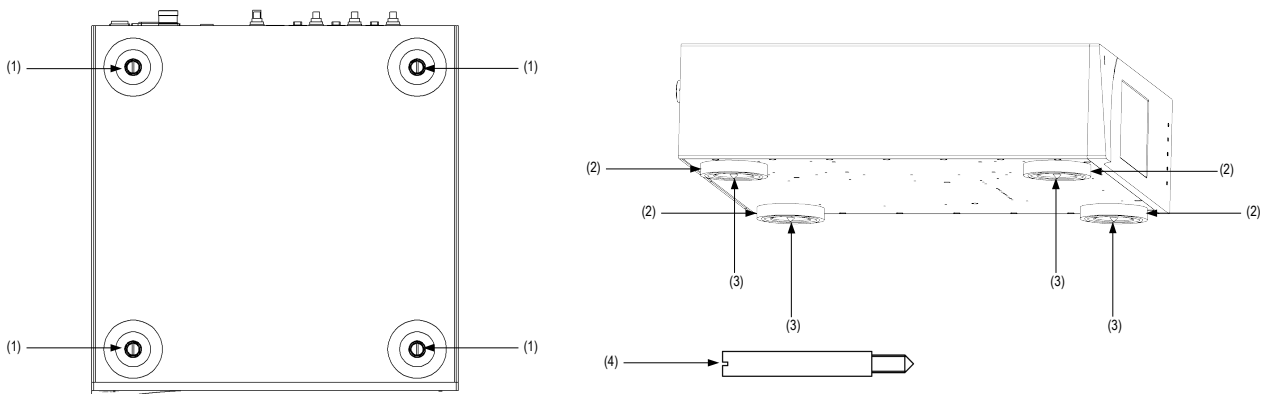

Adjustment shafts, feet and spikes



- (1) Adjustment shafts. Insert the adjustment spikes and use the provided screwdriver to secure and adjust individual spikes
- (2) Feet
- (3) Adjustment spike heads (when inserted into the adjustment shafts)
- (4) Adjustment spike

Never stack any component other than CH's on your P1. Never use the aluminum shaft covers (top covers) when another CH component is to be stacked on top of your P1.

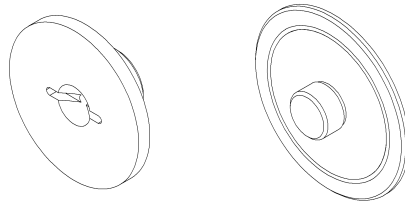

Shaft covers (left: stacking cover, right: top cover)

5 Connections

This section provides information on how to connect your P1 phono stage to the rest of your system. Please connect your P1 in the same order as this chapter describes, starting with the audio connections and ending with the mains connections.

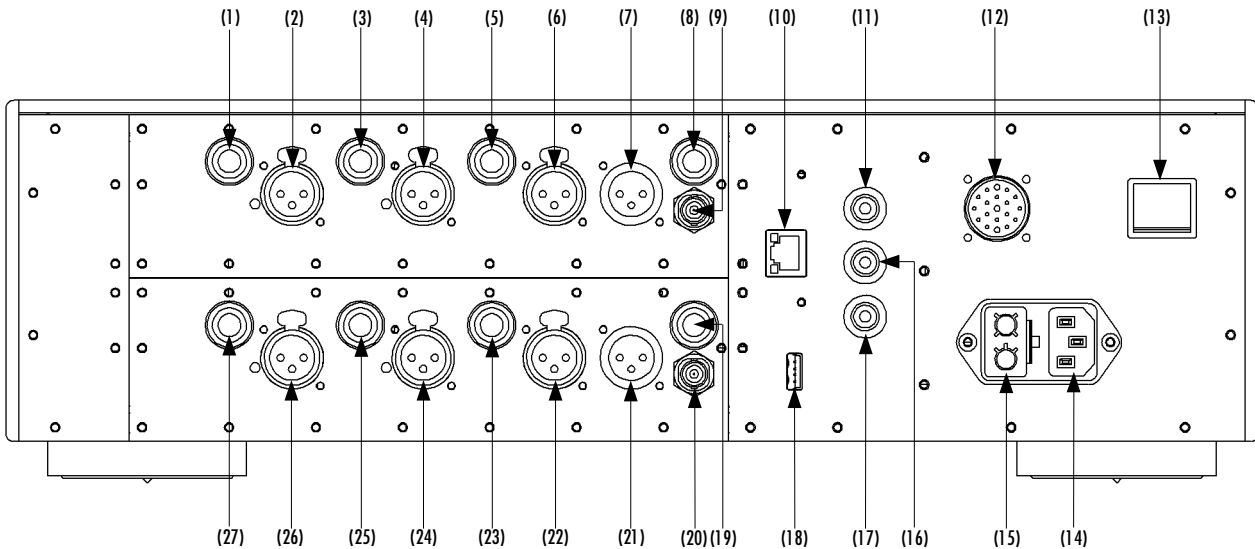

P1 rear panel connections

- (1) RCA left MC1 current mode input
- (2) XLR left MC1 current mode input
- (3) RCA left MC2 current mode input
- (4) XLR left MC2 current mode input
- (5) RCA left MM/MC voltage mode input
- (6) XLR left MM/MC voltage mode input
- (7) XLR left output
- (8) RCA left output
- (9) BNC left output
- (10) Ethernet port for command interface
- (11) Analog ground connector 1. Can be connected to a tonearm's ground wire using provided jumper banana adapter
- (12) External power supply connector for X1 power supply option
- (13) Power on/off switch
- (14) Power cord receptacle
- (15) Power fuse and voltage selection
- (16) Analog ground connector 2. Can be connected to a tonearm's ground wire using provided jumper banana adapter
- (17) Earth connector. Internally connected to digital ground
- (18) USB port for software updates
- (19) RCA right output
- (20) BNC right output
- (21) XLR right output
- (22) XLR right MM/MC voltage mode input
- (23) RCA right MM/MC voltage mode input

- (24) XLR right MC2 current mode input
- (25) RCA right MC2 current mode input
- (26) XLR right MC1 current mode input
- (27) RCA right MC1 current mode input

5.1 Audio connections

The P1 unit is composed of two identical phono stage boards, either located in one (Dual Monaural setup) or in two separate enclosures (True Monaural setup). Each board processes one audio channel (Left respectively Right channel). The way to connect the P1 to your turntable will depend on the type of cartridge you intend to use.

Each channel contains 3 inputs. Two of them are in current mode while the third one is in voltage mode (see section 1.1 for more details). For ease of use and convenience, each input has two types of connectors, XLR and RCA. Both connectors are in parallel, therefore only one connector per input must be used at any one time. However the three inputs are totally independent from each other, allowing up to three different cartridges to be connected at all times.

- The MC1 and MC2 current inputs are mainly dedicated to MC cartridges. Although connecting an MM cartridge to a current input will do no harm to the cartridge nor the P1 input, the overall gain achieved in the phono stage will probably be too low, even with the P1 gain set to maximum. The gain of a current input is inversely proportional to the cartridge's internal resistance: the lower the internal resistance, the higher the gain. MC cartridges have an intrinsic low resistance and will therefore work well on a current input. On the other hand, most MM cartridges have a too high internal resistance and will therefore be best suited to the voltage input. Besides, current inputs don't require any cartridge impedance loading, simplifying the system setup.
- The MM/MC voltage input can be used with all types of cartridges as well as with step-up transformers. On a voltage input, impedance loading is crucial to counteract the undesired effects a cartridge (and the associated interconnections) read in voltage mode will exhibit. The aim is to achieve a frequency response (amplitude of the signal versus frequency) as flat as possible (the amplitude variation between signals of different frequencies is minimal). The P1 voltage input provides a selection of over five hundred resistance values one can choose from, as high as 100 kOhms and down to 20 Ohms. As adjusting a frequency response isn't a trivial operation, the P1 features an internal measurement system combined with a DSP (Digital Signal Processing) device that analyzes and displays the frequency response of the system to help the user select optimum loading based on objective criteria (measurement and analysis of frequency response) as well as subjective preferences (one can also listen to the real-time effect of changing the cartridge loading on-the-fly). The loading can be freely modified at any time from the user interface. Besides, as the voltage input holds two connectors (XLR and RCA) in parallel, one could take advantage of the unused connector to add any desired (including non-resistive) loading depending on the system conditions and one's sound personal tastes. On the RCA, the loading would be applied between tip and ring while it would be applied between pins 2 and 3 of the XLR.
- The P1 output stage is equipped with both balanced and single-ended types of connections, XLR, RCA and BNC. The high bandwidth, ultra low noise and distortion discrete amplifier provides an ideal connection to the downstream unit. We recommend that the output stage doesn't get loaded with an impedance lower than 10 kOhms (the input impedance of the unit connected to the P1 should be greater than 10 kOhms). If for example the P1 is connected to an L1 preamplifier, it is recommended to set the L1 impedance to High-Z on the input the P1 is connected to.

5.2 Ground connection

The back panel of the P1 unit is fitted with 4mm banana sockets. The black sockets are connected to audio ground while the yellow and green socket is connected to mains earth. These sockets can be used to connect the ground of the turntable. Experimentation will define which socket to use. A couple of banana plugs are provided with the P1 unit. The ground lead from the turntable can be screwed to the banana plugs which in turns can be inserted into the back panel sockets.

5.3 X1 optional External Power Supply connector

This connector allows to connect the X1 External Power Supply unit. A custom made interconnect cable delivered with the X1 unit plugs into this connector, allowing to reach the next step in power supply regulation. The P1 unit detects at power up that the X1 is connected and leaves its mains section off and uses to the X1 power supplies instead. **Please note that the P1 AC mains socket must still remain plugged to the AC wall socket.**

5.4 Ethernet port

The Ethernet port is used in the following instances:

- To control the P1 unit settings via the CH Control Android App running on your tablet. Simply connect the P1 Ethernet port to a standard Ethernet Router (equipped with a wireless access point so it can talk to the tablet) using an Ethernet RJ45 Category 5 cable or better. Using the CH Android App, the P1 settings can be accessed and adjusted on the fly.
- In the True Monaural setup (see chapter 2.2), two P1 enclosures are used. In order for the units to automatically apply the same settings to both channels, the two units must be connected to each other. The simple method is to use an Ethernet crossover cable and connect both Ethernet ports together. Both units are arranged in a Master and Slave configuration defined in the user interface menus (see section 7.6 for more details).
- Both above points can be combined in case of a True Monaural setup where one also wants to control the units via the CH Control App. In this configuration both P1 units should be connected to a router (equipped with a wireless access point so it can talk to the tablet). Both units are arranged in a Master and Slave configuration defined in the user interface menus (see section 7.6 for more details)

5.5 Mains socket and voltage selection

Make sure that the voltage selector at the back of the unit is set to the correct mains voltage with respect to the AC voltage at your location. Connect the power cord to the unit's mains socket and the power cord's plug to a wall socket.

5.6 USB port

The P1 unit runs a firmware that defines the unit's operation. The USB port is used to perform update to the P1 unit's firmware. The firmware update is carried out via a USB stick containing the newer version of firmware. The USB Stick is inserted at the back of the unit into the USB port and the update start command is activated via the front panel user interface.

Please note that the USB port has no other purposes than to update the P1 unit firmware. For more information on unit firmware update, please refer to section 9 of this manual.

6 Operation

The P1 phono stage is operated either from the unit's front panel or from a tablet using the CH Control App.

6.1 Front panel

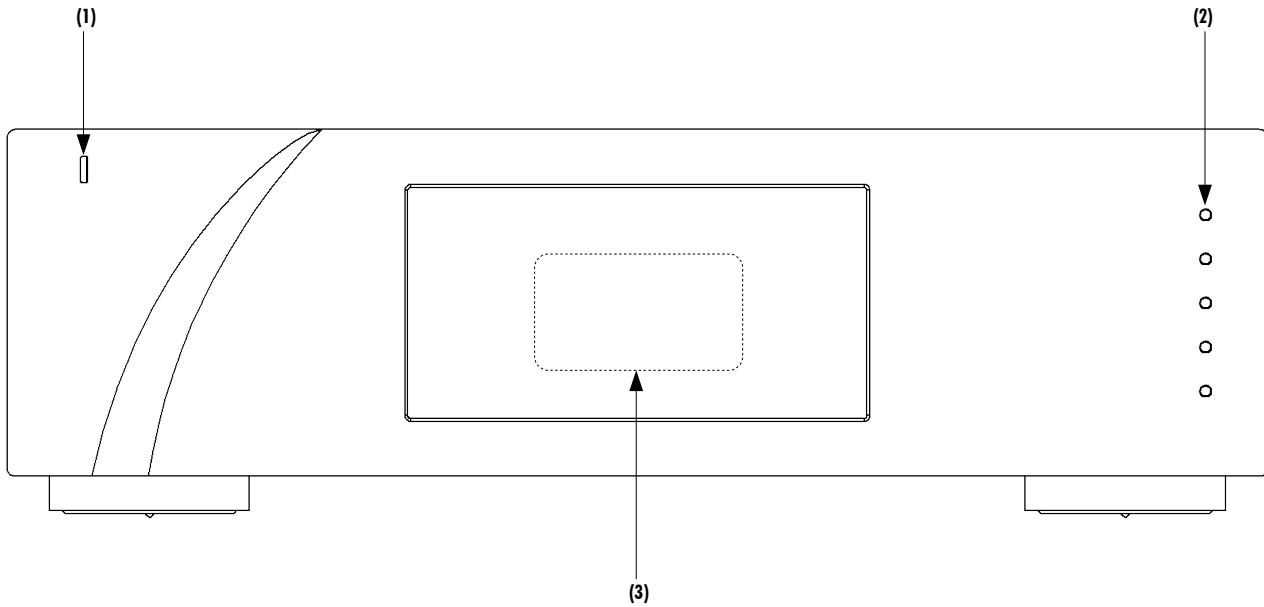

Front panel elements

- (1) Standby LED
- (2) Five user control push-buttons
- (3) Display area (high-definition display)

The standby LED lights up when the unit is in standby. It is turned off by default during operation and shortly lights up whenever it receives an IR remote control command. The LED can also be programmed to remain ON during operation. The display is a high-definition panel with very wide viewing angle, high contrast and high brightness ensuring optimal reading comfort. The color and brightness of the display can be configured to one's taste.

6.2 Front panel push-buttons

The push-buttons located on the front panel of the P1 unit allow the user to access the unit's settings through a series of menus.

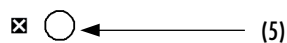
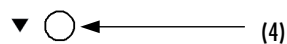
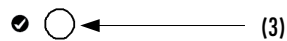
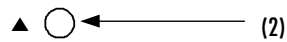

Front panel push-buttons

Button number	Button symbol	Description
1	⏻	Standby (long push) / Mute/Unmute (short push)
2	▲	Up
3	●	OK
4	▼	Down
5	⊠	Cancel

Front panel push-buttons description

6.3 Operating modes

The P1 phono stage has three operating modes: Normal mode, Shortcut modes and Menu mode. Normal mode is used to access the main P1 controls whereas Menu mode is used to fully configure the unit. Shortcuts mode is designed for quick access to selected Menu mode items. Shortcuts are user programmable and most Menu mode items can be selected as Shortcuts.

6.3.1 Normal mode

Normal mode is used for standard phonostage functions. When powered-on, the P1 starts in Normal mode. The display looks as follows:

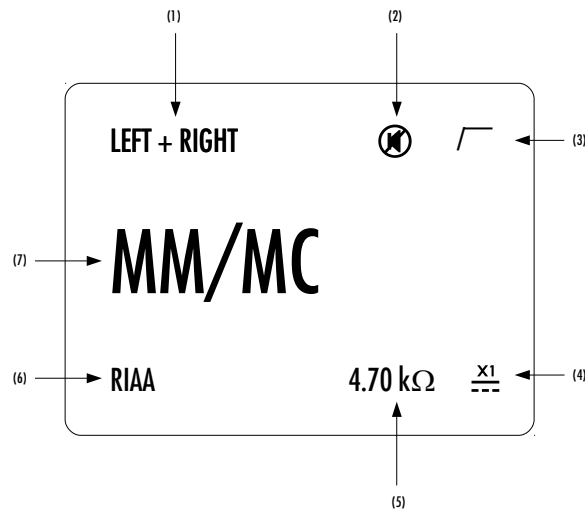

Normal mode display elements

- (1) Handled channel (in true monaural) or channel pair (in dual monaural)
- (2) Mute indication. If the symbol is present, the output is muted
- (3) Subsonic filter indication. If the symbol is present, the subsonic filter is engaged
- (4) External power supply indication. When an external power supply is connected and engaged, symbol is displayed and internal power supply is turned off
- (5) Cartridge loading indication (only for voltage mode MM/MC input)
- (6) Equalization curve engaged
- (7) Selected input source. Each input source can be renamed through P1's menu

Displayed elements depend on the user settings. In the example above, an X1-powered P1 is set as a dual-monaural phono stage, MM/MC voltage mode input is selected. The RIAA equalization curve is selected, the subsonic filter is engaged and a 4.7 kOhm loading is applied to the cartridge. The P1 is muted.

Following table shows the actions of the front panel push-buttons in Normal mode.

Front face push buttons	Unit State	Unit Action
, short push	STANDBY Any other state	Wake from STANDBY Mute/Unmute
, long push	STANDBY Any other state	Wake from STANDBY Go to STANDBY
	Any state	Selects next input
	Any state	Enter Shortcuts mode
	Any state	Selects previous input
	Any state	No effect

Push-buttons actions in Normal mode

6.3.2 Shortcut Mode

The P1 phono stage settings are accessible through a set of menus as described in the next sections. However, to have quick access to the most frequently used configuration menu items, the P1 offers the concept of Shortcuts. Shortcuts are fully programmable and the user may choose almost any configuration parameter as a Shortcut. There are up to 6 user programmable Shortcuts. To learn how to program individual Shortcuts, please refer to the SHORTCUTS menu item in the next section.

Shortcuts are accessed from Normal mode by a push of the OK [●] button on the front face. Additional OK [●] push skips to the next Shortcut. The last Shortcut is always dedicated to entering the Menu mode (SETUP). On this last Shortcut, an OK [●] push will return to Normal Mode and an UP [▲] push will enter the Menu mode. The individual parameter for a given Shortcut is modified using UP [▲] or DOWN [▼] buttons. If there is no user action for about 10 s the unit will revert to Normal mode.

The following table shows the actions of the push-buttons for Shortcuts.

Front face push buttons	Unit State	Unit Action
STANDBY [⏻] Short Push	Any state	Mute/Unmute
STANDBY [⏻] Long Push	Any state	Go to STANDBY
UP [▲]	Shortcuts (except last) Last Shortcut (SETUP)	Modify parameter up (when available) No action
OK [●]	Shortcut (except last) Last Shortcut (SETUP) or after current Shortcut has been modified	Skip to next Shortcut Exit Shortcuts mode (Normal mode)
DOWN [▼]	Shortcuts (except last) Last Shortcut (SETUP)	Modify parameter down (when available) Enter Menu mode
CANCEL [⌫]	Shortcuts	Exit Shortcuts mode (Normal mode)

Push-buttons actions for Shortcuts

The GAIN Shortcut gives a good illustration of how to navigate a Shortcut screen. Navigating other Shortcuts is similar.

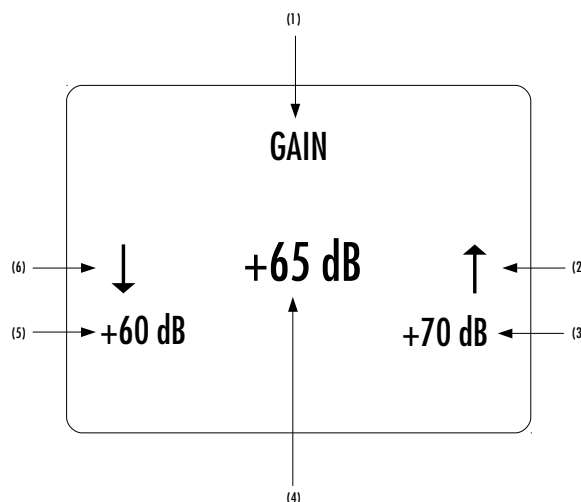

GAIN Shortcut display elements

- (1) Shortcut title (Parameter being adjusted)
- (2) Arrow indicating UP button [▲] if applies. The item below indicates the next parameter value (up direction)
- (3) Next Parameter Value if UP button [▲] is pushed (parameter up)
- (4) Current Parameter Value
- (5) Next parameter value if DOWN button [▼] is pushed (parameter down)
- (6) Arrow indicating DOWN button [▼] if applies. The item below indicates the previous parameter value (down direction)

The last Shortcut (SETUP) is always the same and cannot be removed or altered. It gives access the Menu mode to access the detailed setup of the unit.

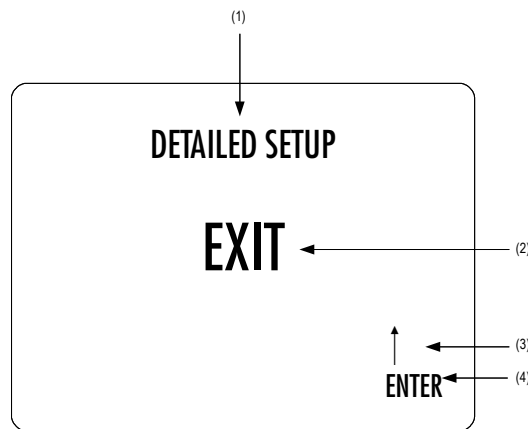

DETAILED SETUP Shortcut screen

- (1) Shortcut title. It indicates that Detailed Setup (Menu mode) can be entered at this stage
- (2) Current value of the parameter. Default action is to exit (go back to Normal mode)
- (3) Arrow indicating UP button [▲]
- (4) Next parameter value. If UP button [▲] is pushed, the unit enters into Menu mode

6.3.3 Menu mode

The Menu mode allows the Configuration and Setup of the P1 phono stage. Menu mode is entered from the last Shortcut item (see above). From Normal mode, enter the Shortcut mode by pushing the OK [●] button. By successive OK [●] button pushes, step to the last Shortcut item (DETAILED SETUP) and push the TOP [▲] button once to enter the Menu mode.

Navigation in Menu mode is based on UP [▲] and DOWN [▼] buttons to select an item or to change a value. The OK [●] button is used for validation and CANCEL [⊠] to exit without saving.

Front face push buttons	Unit Action
STANDBY [⏻] Short Push	Mute/Unmute the unit
STANDBY [⏻] Long Push	Put the unit into Standby
UP [▲]	Move to next menu item upward
OK [●]	Enter next menu level or Validate choice (save setting)
DOWN [▼]	Move to next menu item downward
CANCEL [⊠]	Return to previous menu level without saving

Push-button actions in Menu mode

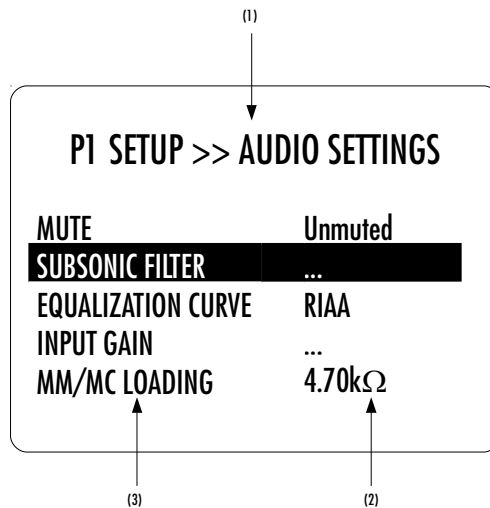

P1 SETUP >> AUDIO SETTINGS menu items

- (1) Menu title. P1 SETUP >> AUDIO SETTINGS shows that the parent menu is P1 SETUP. By pushing the CANCEL [⏏] button, the unit returns to the parent menu.
- (2) This is the Parameter Value column. For each item in the Parameter column, the Parameter Value item on the same line indicates the current value of the Parameter.
- (3) This is the Parameter column. The currently active Parameter is highlighted. Use the UP [▲] and DOWN [▼] buttons to navigate from Parameter to Parameter, and the OK [⏏] button to enter the edition mode of that parameter.

Once a terminal Parameter (e.g. a Parameter not giving access to a further sub-menu) is selected by pushing the OK [R] button, the P1 displays the corresponding Parameter adjustment screen. Following example shows the AUDIO SETTING >> EQUALIZATION CURVE Parameter adjustment screen. Other Parameters are similar but may show more (or less) choices for the Parameter value. Once a Parameter is set to the desired value, an OK [⏏] button push saves the new Parameter Value and gets back to the parent level (save and exit). On the other hand, a CANCEL [⏏] button push gets back to the parent menu (in the case of this example: AUDIO SETTING), but possible modifications of the Parameter Value are discarded (exit without saving).

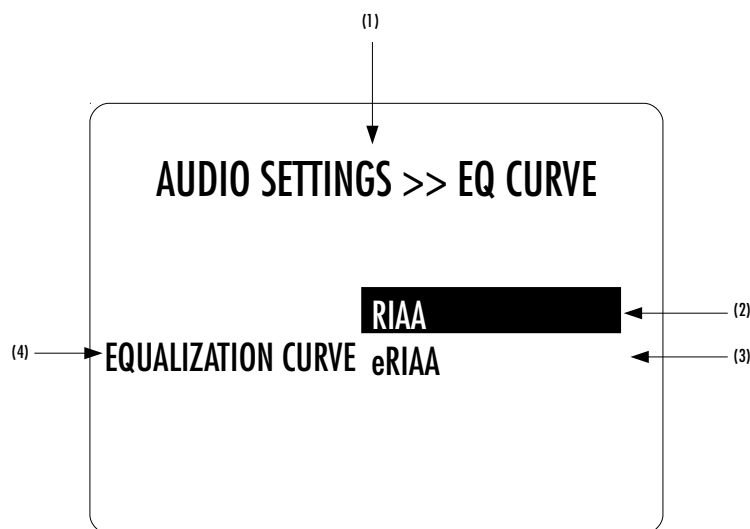

AUDIO SETTINGS >> EQUALIZATION CURVE menu items



- (1) Menu title. AUDIO SETTINGS >> EQUALIZATION CURVE shows that the parent menu is AUDIO SETTINGS. To access the parent menu, push the CANCEL [⌫] button
- (2) The current Parameter Value is highlighted. Push the UP [▲] or DOWN [▼] buttons to navigate through Parameter Values
- (3) Other possible Parameter Value(s). Number of other Parameter Value(s) depends on Parameter
- (4) Parameter for which the Parameter Value can be modified in the current menu.



7 Unit menus

Configuration of your P1 phono stage is accomplished by setting up parameters in the Menu mode (see chapter 6 on how to access the Menu mode and how to navigate through menu items).

Please note that configuring your P1 can easily be done on a tablet using the CH Control Android App. Please refer to chapter 5.4 for more information about how to link the P1 to your tablet. Besides, for more information about the CH Control App, please visit our Facebook page (www.facebook.com/chprecision) where you can watch a video describing the main functionalities of the App.

There are six main menus used to configure the P1:

- **AUDIO SETTINGS:** Allows to adjust audio related parameters
- **DISPLAY SETTINGS:** Allows to adjust the front panel display related parameters
- **SHORTCUTS:** Allows to assign and modify Shortcuts for user interface customization
- **FACTORY SETTINGS:** Indicates the software version and allows to update it. Also allows to return to default factory settings and run setup wizards
- **INSTALLED BOARDS:** Indicates which boards are installed and what audio channel they refer to
- **NETWORK:** Provides information about the network setup and enables its configuration

7.1 AUDIO SETTINGS menu

PARAMETER	PARAMETER VALUES	REQUIRED OPTIONS	REMARKS
MUTE	Muted Unmuted	None	None
SUBSONIC FILTER (individually selectable for each input)	Off On	None	None
EQUALIZATION CURVE	RIAA eRIAA EMI COLUMBIA DECCA TELDEC	None None EQ Option board EQ Option board EQ Option board EQ Option board	RIAA and eRIAA equalization curve are available as standard. Enhanced RIAA (eRIAA) adds the unofficial Neumann time constant to the standard RIAA curve. Four more equalization curves can be selected if the optional EQ board is loaded on the phono boards.
INPUT GAIN (individually selectable for each input)	+35 dB +40 dB +55 dB +60 dB +65 dB +70 dB I/V + 0 dB	MM/MC voltage input MM/MC voltage input MM/MC voltage input MM/MC voltage input MM/MC voltage input MM/MC voltage input MC current input	+35 dB and +40 dB are usually used for MM cartridges connected to the MM/MC voltage input. +55 dB to +70 dB are usually used for MC cartridges connected to the MM/MC voltage mode input. I/V + 0 dB to I/V + 25 dB are used for low internal



	I/V + 5 dB I/V + 10 dB I/V + 15 dB I/V + 20 dB I/V + 25 dB	MC current input MC current input MC current input MC current input MC current input	impedance MC cartridges connected to the MC1 or MC2 input. The lower the cartridge resistance is, the lower the gain setting can be.
MM/MC LOADING	20 Ohm ... 100 kOhm more than 500 values available	MM/MC voltage input only	Follow the cartridge manufacturer's recommendation, and use the loading wizard detailed in chapter 1.3 and 8.4 to refine that value. See chapter 7.4 to find this setting.

7.2 DISPLAY SETTINGS menu

PARAMETER	PARAMETER VALUES	REQUIRED OPTIONS	REMARKS
DISPLAY MODE	Status Off	None	Selects what to display when the unit is idle for several seconds: General status page or turn off the display.
LED ON/OFF	On Off	None	Allows to select if the LED is off or on when the P1 is on
INPUT RENAMING	<i>Any string</i>	None	Used to rename any input in the P1
BRIGHTNESS NORMAL	10% 20% ... 100%	None	Sets the display brightness when the unit is operated.
BRIGHTNESS DIMMED	10% 20% 30%	None	Sets the display brightness when the unit is left idle for several seconds.
COLOR	Red Green Blue White Yellow Magenta Cyan Custom color Edit custom color	None	Selects the display color Custom color is a user definable color. To Edit the custom color select the Edit custom color Value. Sub-menus allow to individually configure Red, Green and Blue components (RGB) of the custom color.
GAMMA	RGB and global brightness gamma curve correction, +/-30%	None	Fine adjustment the gamma scale of the RGB components of the display. Allows to have perfectly dark background and to match other CH Precision unit's display color, even at low brightness



7.3 SHORTCUTS menu

PARAMETER	PARAMETER VALUES	REMARKS
SHORTCUT 1	Any Parameter of the AUDIO SETTINGS and DISPLAY SETTINGS menus or None	If SHORTCUT 1 is not defined, Parameter value for SHORTCUT 1 is set to 'None'. SHORTCUT 2 to 6 are not displayed in this case.
SHORTCUT 2	Any Parameter of the AUDIO SETTINGS and DISPLAY SETTINGS menus or None	If SHORTCUT 2 is not defined, Parameter value for SHORTCUT 2 is set to 'None'. SHORTCUT 3 to 6 are not displayed in this case.
SHORTCUT 3	Any Parameter of the AUDIO SETTINGS and DISPLAY SETTINGS menus or None	If SHORTCUT 3 is not defined, Parameter value for SHORTCUT 3 is set to 'None'. SHORTCUT 4 to 6 are not displayed in this case.
SHORTCUT 4	Any Parameter of the AUDIO SETTINGS and DISPLAY SETTINGS menus or None	If SHORTCUT 4 is not defined, Parameter value for SHORTCUT 4 is set to 'None'. SHORTCUT 5 and 6 are not displayed in this case.
SHORTCUT 5	Any Parameter of the AUDIO SETTINGS and DISPLAY SETTINGS menus or None	If SHORTCUT 5 is not defined, Parameter value for SHORTCUT 5 is set to 'None'. SHORTCUT 6 is not displayed in this case.
SHORTCUT 6	Any Parameter of the AUDIO SETTINGS and DISPLAY SETTINGS menus or None	If SHORTCUT 6 is not defined, Parameter value for SHORTCUT 6 is set to 'None'.

7.4 FACTORY SETTINGS menu

PARAMETER	RELATED ACTION/VALUE	REQUIRED OPTIONS	REMARKS
FIRMWARE VERSION	<i>Firmware version</i>	None	<i>Firmware version</i> indicates the version of the current firmware. Format is <i>x.y</i> . This parameter is read only.
UPDATE FIRMWARE	Update	None	Selecting 'Update' launches the P1 firmware update process. A USB flash disc drive with a valid set of firmware must be inserted in the A-shaped USB port
RESET ALL SETTINGS	Reset	None	Selecting 'Reset' returns the P1 to its factory settings.
SERIAL NUMBER	<i>Serial number</i>	None	<i>Serial number</i> indicates the serial number of the P1. This parameter is read only.
SHORTCUTS	Default mapping	None	Selecting 'Default Mapping' returns the P1's Shortcuts to their factory settings. Factory settings are detailed in the Specifications section.
INPUT GAIN	Set default gain	None	Set back the gains to minimal values.



INPUT NAMES	Default names	None	Set back all input names to their default value
GAIN SELECTION WIZARD	Start wizard	Track 1 on side 2 of the CH Precision P1 phonostage calibration record must be used	This wizard helps obtaining the best signal to noise ratio and a P1 output level close to standard line level sources (such as the CH Precision C1 DAC)
MM/MC LOADING WIZARD	Start wizard	Track 1 on side 1 of the CH Precision P1 phonostage calibration record must be used	More details on that wizard can be found in chapter 1.3 and 8.4.
NETWORK KNOWLEDGE	Reset	None	Clears the P1 's memory of other CH Precision devices it has discovered through the TCP/UDP proprietary protocol.

7.5 INSTALLED OPTIONS menu

PARAMETER	PARAMETER VALUES	REMARKS
TOP SLOT	Left or Right phono board	Parameters are Read Only
BOTTOM SLOT		

7.6 NETWORK SETTINGS menu

PARAMETER	PARAMETER VALUES	REQUIRED OPTIONS	REMARKS
STATUS	IP address Product type MAC address	Connection to a router via its RJ-45 Ethernet port	List of CH Precision devices and Android remote controls detected by the P1 (product type, IP and MAC addresses) Parameters are Read Only
ROLE	Offline Power master master Slave Custom	Connection to a router via its RJ-45 Ethernet port	When physically connected to a network, the P1 can ignore this network (offline) or connect to it as being the master (it will broadcast its state for slaves to synchronize) or as a slave (it will ignore IR remote control commands and synchronize to the master instead). When set as power master, even the on/off state of this unit will be imposed to slaves. Custom allows to fine tune which specific parameter is synchronized through the network. This networking facility enables information sharing among CH products (such as input selection, gain setting and cartridge loading for true monaural P1



			Left + P1 Right configurations).
ROOM NUMBER	1 ... 6	Connection to a router via its RJ-45 Ethernet port	Define the room in which the P1 is for multiroom applications. This prevent CH Precision units connected to the same network but located in different systems/rooms to interact with each others.
IP SETTINGS	Auto (DHCP) Direct-Link Manual	Connection to a router via its RJ-45 Ethernet port or to another true monaural P1 with a	Auto should be selected if the P1 is connected to a router with DHCP server feature. Direct link can be used when 2 true monaural P1 are connected together but not to a router. They can be directly connected with a crossover network cable or being both connected to a switch. Manual is an advanced setting for users willing to manually configure the IP address and mask of the P1.
WAKE-ON-LAN	No Only if PoE Yes	Connection to a router via its RJ-45 Ethernet port	If No is selected, the P1 can't be waken from standby by the app. Standby mode will consume less than 0.5W. If Only if PoE is selected, the P1 can only be waken from standby by the app if connected to a Power-over-Ethernet switch. Standby mode will draw less than 0.5W from the mains plug. If Yes is selected, the P1 can always be waken from standby by the app. Standby mode will draw a couple of watts from the mains plug.



8 Adjust the P1 to the cartridge

For each cartridge connected to a P1 input, the phonostage provides several wizards to help set up the system. Users are advised to take the following steps:

1. Select the type of P1 input the cartridge will be connected to.
2. If the voltage mode MM/MC input is used, select an initial loading value.
3. Select the optimal gain with the help of the gain selection wizard and the provided 45 RPM record.
4. If the voltage mode MM/MC input is used, run the loading wizard in conjunction with the provided test record to optimize the loading of the cartridge.

The following paragraphs will explain in more detail each of these steps

8.1 Input type selection

High quality low output low internal resistance moving coil cartridges usually work best at delivering current than voltage. When such a cartridge is directly connected to the P1, MC current mode input should be used.

In most other cases (moving magnet, moving iron, high output moving coil, and even low output low internal resistance moving coil connected through a step-up transformer), the MM/MC voltage mode input should be used. In that case, optimal loading should be selected to flatten the voltage frequency response of the cartridge.

8.2 Initial loading selection

For cartridges connected to the MM/MC voltage mode input of the P1, the amount of loading applied to the cartridge by the P1 can greatly influence not only the frequency response of the cartridge, but also the level of the signal. This is why a reasonably accurate loading must be selected prior to any gain selection. If the cartridge manufacturer advises on a particular loading value, it should be set (AUDIO SETTINGS > MM/MC LOADING) as a starting point. If a range of values is provided by the cartridge manufacturer, the highest value should be set. If no guidance can be found, CH Precision recommends to select an initial loading value of 100 kOhm for MM cartridges while an initial value of in the region of 5 kOhm should be suitable for most MC cartridges.

8.3 Optimal gain selection

In order to obtain the best signal-to-noise ratio and a P1 output level close to line level sources (such as the CH Precision C1 DAC), a gain wizard has been programmed into the P1. It can be found in FACTORY SETTINGS > GAIN SELECTION WIZARD.

It is designed to be used in conjunction with track 1 of side 2 of the provided CH Precision P1 phonostage calibration record. Simply follow the steps described in the P1 wizard screens.

8.4 Refined loading selection

Once the gain has been properly selected, the loading of the MM/MC voltage mode input can be further fine-tuned using the loading wizard found in FACTORY SETTINGS > MM/MC LOADING WIZARD. This procedure performs more than 20 frequency response curve acquisition per run, each time with a different loading value spread evenly on a user-defined range of values. Once these acquisitions are completed, you can scroll across all analyzed loading value. For each value, the frequency response curve of the entire system is displayed on the P1 screen, along with level attenuation and curve flatness. Based on this information and auditory feedback (each loading being applied in real time, you can play your favorite reference record as you scroll across measurements), the loading that provides best results among all measurement can be selected. This wizard can be run more than once, each time refining the measured loading range around the new optimal value.



9 Firmware update

9.1 Preparing the USB Stick

The firmware of all the CH Precision units can be updated using the USB port located at the back of the unit. Before starting the firmware update, it is necessary to load a USB stick with files containing the new firmware. Use a FAT32 formatted USB 2.0 stick. Please note that some USB sticks might not be detected by the P1 USB port. CH Precision recommends the use of Sandisk USB 2.0 sticks.

The following procedure describes how to load the USB stick with the correct files:

1. Download the latest P1 firmware file from www.ch-precision.com
2. Decompress the .zip file and copy the decompressed files to the root of your USB stick. After doing so, your USB stick should contain the following files:
 - P1_XXX.dsl
 - P1_XXX.mcl
 - P1_XXX.OP1

where 'XXX' indicates the firmware revision.

Make sure all three files are present at the root of your USB stick. Any missing file will make the firmware update procedure fail.

9.2 Updating the unit's firmware

1. Perform the operations described in section 9.1
2. Connect the USB stick to the USB port located at the back of your P1 unit
3. Navigate to the FACTORY_SETTINGS menu (see section 6) and select the UPDATE_FIRMWARE item
4. Start the Firmware Update process by pushing the OK (⏻) button. Please note that the unit will perform a Reset (the display briefly turns off and on) during the procedure
5. Once the firmware update is complete, the unit automatically goes into Standby. Remove the USB stick and turn the unit on. The new firmware is now active. To verify that the firmware update is effective, navigate to the FACTORY_SETTINGS menu and select the FIRMWARE_VERSION item. The displayed firmware revision should match the firmware revision on the files copied to the USB stick

Note: The firmware update process lasts several minutes, **do NOT interrupt it!**

When performing a firmware update, do NOT press any of the unit's front panel push-buttons, do NOT unplug the unit from the AC wall socket and do NOT turn the mains power switch off. Interruption of the firmware update procedure may result in corrupted firmware and a non functioning unit. In case something went wrong during a firmware update and the unit malfunctioning, apply the emergency firmware update procedure described in the next section.

9.3 Emergency firmware update procedure

Perform the following Emergency Firmware Update procedure if your unit does not power up normally.

1. Perform the operations described in section 9.1
2. Turn the unit off (back panel power switch to OFF)



3. Push and keep the STANDBY (⏻) button pushed and power up the unit (back panel power switch to ON). Keep the STANDBY (⏻) button pushed for a couple more seconds after you turned the unit on.
4. The unit performs the emergency firmware update. Once the operation is complete, the unit automatically goes into Standby. Remove the USB stick and turn the unit on. The new firmware is now active. To verify that the firmware update is effective, navigate to the FACTORY_SETTINGS menu and select the FIRMWARE_VERSION item. The displayed firmware revision should match the firmware revision on the files copied to the USB stick
5. If the emergency firmware update procedure fails, try the same procedure again using a different USB stick. If the failure persists, turn off your unit and contact your authorized dealer for assistance.

Note: The emergency firmware update procedure lasts several minutes, **do NOT interrupt it!**

10 Troubleshooting

Error	Action
No power	Check the AC power cord Check the power switch at the back of the unit Check the mains fuses on the AC power cord receptacle
No sound (general)	Check that your turntable is playing, and the cartridge is properly connected to the tonearm Check that the tonearm is properly connected to the desired P1 input Check that the correct input is selected on your P1 Try slightly increasing the gain of that input Check that your P1 is properly connected to your line level preamplifier
No sound (“Ⓜ” is displayed)	Your P1 is muted (display area 2 Ⓜ must be off for the unit to output signal). Unmute using the top front panel button
Lost in the settings?	Restore the default factory setting and start your setup again
Firmware update fails	Perform the emergency software update procedure
USB stick for firmware update is not detected	Try another brand of USB 2.0 stick. CH Precision recommends the use of Sandisk USB 2.0 sticks

Troubleshooting

If the error persists, disconnect the unit from the AC wall socket and from the rest of your system and contact your authorized dealer for assistance.



11 Specifications

General	
User control	Front panel push-buttons and/or CH Control Android App
Display	480×272 24bits RGB AMOLED
Power supply	Selectable 100V, 115V or 230V AC, 47Hz to 63Hz
Power consumption (Standby)	< 1W
Power consumption (Normal operation)	40W average
Operating conditions	Temperature: +5C to +35C, humidity: 5% to 85% (no condensation)
Dimensions (W x D x H)	440mm x 440mm x 120mm (main body) 440mm x 480mm x 133mm (overall including connectors and feet)
Weight	20kg
Firmware update / Control	USB port for firmware update / Ethernet based system control
Playback equalization filters	
Defaults equalization filters	RIAA, enhanced RIAA
Optional equalization filters	EMI, Columbia, Decca and Teldec
Equalization filters accuracy	±0.1 dB
High Pass Filter (Bypassable)	
Filter Order	3rd order (-18dB per octave)
Cut-off frequency	10Hz
Current inputs	
Connections	1 x RCA, 1 x XLR per channel on each input
Input impedance	<0.1 Ohms
Gain for a 1 Ohm internal resistance cartridge (at 1 kHz)	+70dB (P1 gain setting: I/V+0dB) +75dB (P1 gain setting: I/V+5dB) +80dB (P1 gain setting: I/V+10dB)
Gain for a 10 Ohm internal resistance cartridge (at 1 kHz)	+65dB (P1 gain setting: I/V+15dB) +70dB (P1 gain setting: I/V+20dB) +75dB (P1 gain setting: I/V+25dB)
Voltage input	
Connections	1 x RCA, 1 x XLR per channel
Gains (at 1 kHz)	+35dB, +40dB, +55dB, +60dB, +65dB, +70dB
Input impedance (cartridge load)	Variable from 100 kOhms to 20 Ohms in over 500 steps
Analog outputs	



Balanced outputs	1 x XLR per channel
Single-ended outputs	1 x RCA, 1 x BNC per channel
Output level	Up to 8Vrms (balanced), Up to 4Vrms (unbalanced)
Performances	
Frequency response (-3dB point)	> 400kHz (RIAA equalization filter disconnected), current input selected
Equivalent input noise (EIN)	Without the X1 External power supply connected to the P1: Current inputs: <-135dBu; 1 Ohm termination, gain +70dB, 22kHz BW Voltage input: <-130dBu; 1 Ohm termination, gain +70dB, 22kHz BW With the X1 External power supply connected to the P1: Current inputs: <-138dBu; 1 Ohm termination, gain +70dB, 22kHz BW Voltage input: <-135dBu; 1 Ohm termination, gain +70dB, 22kHz BW
Total Harmonic Distortion + Noise (THD+N)	<0.01%, 1 kHz, output level 3Vrms, 22kHz BW

Design and Specifications subject to change without notice. Weight and dimensions are approximate

Illustrations are informative only and may differ from the actual production model

Enclosure designed by Mana Ishoni

FCC-Notice

Note: This equipment has been tested and found to comply with the limits for a Class B digital device, pursuant to Part 15 of the FCC Rules. These limits are designed to provide reasonable protection against harmful interference in a residential installation. This equipment generates, uses and can radiate radio frequency energy and, if not installed and used in accordance with the instructions, may cause harmful interference to radio communications. However there is no guarantee that interference will not occur in a particular installation.

If this equipment does cause harmful interference to radio or television reception, which can be determined by turning the equipment off and on, the user is encouraged to try to correct the interference by one or more of the following measures:

- adjust or relocate the receiving antenna
- increase the separation between the equipment and the receiver
- connect the equipment into a mains outlet on a circuit different from that to which the receiver is connected
- consult the dealer or an experienced radio/TV technician for help

Disposal – Environmental care

Directive 2002/96/EG of the European Parliament requires consumer electro-technical appliances to be disposed separately and have to be indicated with the following symbol. Should you dispose this component please do so in conformity with local and global legal and environmental regulations and according to best practices. We strongly encourage you to recycle any batteries used with this component.

